

# Towards a multi-agent model to prevent damage caused by cocoa mirids to cocoa pods

E. D. NGOUNOU NTOUKAM<sup>1</sup>  
I. H. TCHAPPI<sup>1,2</sup>

V. C. KAMLA<sup>1</sup>  
S. GALLAND<sup>2</sup>  
S. EMVUDU WONON<sup>3</sup>

Y. MUALLA<sup>2</sup>  
J. C. KAMGANG<sup>1</sup>

<sup>1</sup> University of Ngaoundere, 455 Ngaoundere, Cameroon

<sup>2</sup> CIAD, Univ. Bourgogne Franche-Comté, UTBM, F-90010 Belfort, France

<sup>3</sup> University of Yaounde, Yaounde, Cameroon

ngounoudimitry@gmail.com

## Abstract

*Agriculture in general and cocoa farm in particular is one of the primary sources of income for several African countries. Although quite useful for the development of Africa, cocoa production is faced with several challenges like the diseases of cocoa trees. Mirid (*Sahlbergella singularis*) is the worst pest affecting cocoa production across west Africa causing 30% to 40% of damage on cocoa production. It is difficult to control the mirids' population and its impact on the cacao production. Related works on mirids studied the mirids population as a macroscopic entity without considering local interactions of individual mirids. These models did not consider the behaviours and the environment of mirids which are essential due to their complexity. To overcome these drawbacks, this paper proposes an agent-based model of mirids considering the individual interactions of mirids within the environment. The proposed model consists of agents representing the mirids through their life cycle in cocoa farm environments. It is based on the biological and ecological partial knowledge found in the literature, and is built according to the GAIA methodology. The main assets of this model are the reproduction of the dynamics of the mirids on a cocoa pod and damage caused by them at the micro level for human users (entomologists, agricultural engineers, farmers and decision makers) to thoroughly understand the phenomena and the emergent properties outcomes.*

## Keywords

Mirid, Agent-based modeling, Cocoa, GAIA methodology.

## Résumé

*L'agriculture en général et la culture du cacao en particulier est l'une des principales sources de revenus de*

*plusieurs pays africains. Cependant, la production du cacao est confrontée à plusieurs défis tels que les maladies et l'attaque des insectes nuisibles. Les mirides (*Sahlbergella singularis*) sont les insectes les plus préjudiciables à la culture du cacao en Afrique. Avec 30 à 40 % de dommages sur la production, il est difficile de contrôler la population des mirides ainsi que son impact sur la production de cacao. Les travaux précédents sur les mirides, étudient la population de cet insecte selon le point de vue macroscopique sans tenir compte des interactions locales entre les mirides. Ces modèles ne prennent pas en compte les comportements individuels des mirides et leurs interactions avec l'environnement qui sont essentiels en raison de leurs complexités. Pour remédier à ces insuffisances, le présent article propose un modèle de mirides à base d'agents prenant en compte les interactions individuelles des mirides dans leur environnement. Le modèle proposé est constitué d'agents représentant le cycle de vie du miride sur une cabosse de cacao. Il est basé sur les connaissances biologiques et écologiques du miride, et est construit selon la méthodologie GAIA. Ces modèles ainsi que leurs implémentations sont destinés à des utilisateurs tels que les entomologistes, les ingénieurs agronomes, les agriculteurs et les décideurs. Cela leur permettra de mieux comprendre les phénomènes émergents dues aux mirides ainsi que leurs propriétés.*

## Mots Clés

Mirid, Modélisation à base d'agents, Cacao, Méthodologie GAIA.

## 1 Introduction

With more than 72% of worldwide cocoa production, Africa (Ivory Coast, Ghana, Nigeria and Cameroon) is currently the main producer of cocoa [20]. Cocoa is cultivated by smallholder with lower livelihood, yet it

is an important source of revenue for these farmers.

African production faces numerous difficulties like : ageing of farmers, ageing of plantations, non-respect of good agricultural practices, presence of diseases and pests [10]. Cocoa Swollen Shoot Virus (CSSV) and cocoa Black Pod Rot (BPR) are the most two diseases that seriously affect African cocoa production [7]. Additionally, *Sahlbergella singularis* and *Distantiella theobroma* are the most two pests that negatively impact production of cacao in all African producer countries [6]. Between these two species, *Sahlbergella singularis* is the most common and most harmful [6]. These two species, also called mirid bugs, feed principally on cocoa (*Theobroma cacao*). Mirids feed on pods and shoots and they cause the drying up of leaves and a quick destruction of the cocoa canopy. The immature (five instars) and adult stages of these sucking insects feed on the sap of young branches, by injecting a digestive saliva [3].

Due to the considerable thickness of the pod cortex, damages caused by mirids are relatively superficial on pods and there is no direct link between the intensity of feeding lesions on mature pods and bean quality [6]. Nevertheless, young fruits (less than 10 cm in length and less than 2 months old) also called chérelles, can be seriously damaged by the mirid's feeding lesions. These feeding lesions can increase the abortion of young fruits and thus impact production [7].

The main strategy to fight against mirids is the use of insecticide. Although alternative cocoa pest control methods have been developed to fight against mirids. They include cultural management [16], varietal management [1], as well as semi-chemical management with the use of synthetic sexual pheromone traps [1, 23]. However, their effectiveness remains limited. Cocoa is cultivated in tropical agro-forests which are characterized by complex associations of multi-functional and uneven-aged trees and crops [19]. In such environments, it is not obvious to count mirid individuals (immatures and adults) or evaluate the impact of their actions on cocoa plant. Agent-based approaches are suitable to model complex systems [8, 26, 25]. They seem to be the most relevant option to model the dynamic behavior of mirids at the micro level in order to understand mirids behavior and thus forecast its evolution and adopt an efficiency control strategy. The aim of this work is therefore to propose an agent-based model for the mirids dynamic. To this end, an initial agent-based model is proposed based on the mirid's life cycle. We make some representations of a mirid agent on a cocoa pod to present how it progresses. In order to be logical and clear, we follow the GAIA methodology [26]. In fact, GAIA methodology is well-suited to design and build systems in complex and open environments at both micro and macro levels [8] such as the motion and evolution of mirids in

a cocoa farm.

This work is on progress and the paper focuses only on the interactions of mirids in the environment. In the future, other interactions will be considered such as the interaction with human users (entomologists, agricultural engineers, farmers and decision makers). Therefore, we shall make sure that the target people will be able to understand our models and simulation results. To do so, the simulation should explain to the users about the behaviours of all agents and their interactions.

The paper is organized as follows : Section 1.1 highlights a brief overview on theoretical models of mirids. Section 2 presents our agent-based model of the life cycle of mirids based on the GAIA methodology. Section 3 discusses the need for explainability and how to achieve it and section 4 concludes the work and gives the prospective directions.

## 1.1 Related Works

It is important to understand mirid's life cycle and to have information about its biology and ecology. The life cycle of a mirid is of three phases : *egg*, *nymph* and *adult*.

Mirids develop on the cocoa pod. Females insert eggs in cocoa living tissues, and egg development requires healthy tissues to be completed [5]. The embryonic development of a mirid is between 15 and 20 days in average with minimum 9 days and 21 days maximum [5]. After the embryonic phase, the egg becomes a nymph. On average, the life-cycle duration (eggs to adults) of mirids is 40 days with a minimum of 36 days [4] and a maximum of 50 days [5]. The rate of hatching in the laboratory is between 30% and 82%, but it could be up to 96.53%. During the nymph stage, the mirid moves on the cocoa tree to feed of the pods and the shoots. The rate of survival of nymphs is around 68% [3]. The sex ratio is 1 female for 0.7 male. After the last phase of nymph, a female mirid (*S. singularis*) starts to mate after 6 to 10 days while the male mirid starts after 2 days [5]. After the mating, a female mirid is considered to be mature, and it can lay her eggs in many pods at different times. To lay an egg, a female mirid needs 4 to 8 days, on average, after the mating. More than 72.1% of female mirids become mature (able to lay eggs) [16].

In average, the fecundity of female mirids is 52.5 eggs, and the fecundity period lasts, on average, for 16 days [24]. The daily survival of mirids adult is around 98.14% for immature females, 92.8% for mature females, and 93% for males [24]. To obtain a new generation, 50 to 60 days are needed on average [16].

In order to understand and forecast the mirid population dynamics, several studies have been done using a variety of approaches and techniques : development of a rearing method [5], sheeting method [15], pheromone

trapping [23, 16] and mathematical modelling [24]. Babin *et al.* [5] developed a rearing method for cocoa mirids in the order to assess the performance using the calculation of life-table parameters and to investigate the relationship between rearing performance, especially female fecundity, and climatic conditions. Sarfo *et al.*, [23] studied the potential of sex pheromone trapping as an alternative environmentally-acceptable method for managing the mirids. Based on the behavioral responses of the mirids to pheromones in traps, parameters were standardized for efficient performance of the traps.

In general, field studies like those of Sarfo *et al.* [23] and Babin *et al.* [4] focus on finding correlations between observed data (mirid populations) and explanatory variables (shade, temperature, rain, pheromone, etc.). Linear regression helps to determine the relationship between variables. Such statistical models can help to explain or forecast relationships between parameters. The limits of such field studies are that they are expensive, and do not allow to test many hypotheses. Additionally, the quality of the acquired data is sometimes poor [16]. Moreover, the laboratory data and field data are not always accordance due to the fact that, in the field, it is plausible that not all parameters that influence mirids are considered. Field data are often site-specific, and extrapolation of their results to other regions is not obvious [9, 12]. In field studies, the combination of many parameters can also pose a severe challenge. A theoretical modelling approach or representation of such an environment could be useful to explore how does the mirid live and which parameters are important to it.

Tapi *et al.* [24] developed a generic mathematical model for mirid populations to better predict its dynamics in a plot under different management strategies. Their first model [24] is a compartmental model with constant or periodic parameters. It is developed based on the mirid life cycle. They have done a theoretical and sensitivity analysis to provide numerical simulations. Following this, Tapi *et al.* [24] developed a second model (a time-delayed model) based on the previous one. The second model was better in terms of considering the developmental time at different stages. After a brief theoretical analysis, they provided numerical simulations with/without control efforts. Mathematical models allow predicting the long-term dynamics of the studied systems. However, the variability between individuals is difficult to represent [22]. Moreover, mirids live in traditional cocoa agro-forests which are complex systems where interactions and components are multiple and different [17]. Although, mathematical models proposed in the literature are easy to prove, they can be difficult to explain to non-mathematicians. Therefore, they are not the best tools to communicate with certain target groups, such as

farmers [18].

The design of each model is founded upon approximations of the pest's biology and behavior on a population level [12]. The models presented in the literature are often dedicated to specific farms, and local interactions of individual mirids are not represented or incorporated explicitly into the population dynamics. In order to better understand the mirid dynamics, it would be useful to consider the local interactions of mirids in space and time. Thus, an agent-based approach seems to be suitable to deal with mirid motion and local interactions. Agent-based modeling is the computational study of social agents interacting in an autonomous manner as evolving systems. It allows the study of complex adaptive systems and facilitates investigations into how macro-phenomena develops from micro-level behavior among heterogeneous sets of interacting agents [13]. Mirids are governed by their biological preferences and limitations as documented in the literature. Therefore, and by representing mirids as individual agents, the resulting relationships between these agents can be used to predict population dynamics of the pest. Additionally, this prediction is more realistic over space and time (based on local interactions) than the ones with the population aggregated mirid models.

In the context of our work where users are in the loop, we think that there is a need for a simplified way to explain the system results to users, and to interact with them and acquire feedback. In our opinion, simulation and visualization are a great way to explain the system and its results, while questionnaires and direct feedback are important to make sure the user in the loop understands the process.

## 2 Multi-agent Model of Mirids

The modelling of our system is based on the second version of GAIA proposed by Zambonelli *et al.* in [26]. They have extended the version of Wooldridge *et al.* [26, 25] towards social issues and open systems. GAIA prescribes following an ordered sequence of steps, an ordered identification of a set of organizational models, and an indication of the interrelationships guiding developers towards the development of a Multi-agent System (MAS). The GAIA methodology starts first with the analysis phase to collect and organize the specifications which are the basis for the design of the computational organization [26]. Then, the architectural design phase defines the most proper organizational structure for the MAS, the topology of interactions in the MAS, and the control regime of these interactions. Finally, the detailed design is responsible for identifying, eventually, the agent model and the services model, which act as guidelines for the actual implementation of agents and their activities. In order to emphasize the microscopic behavior of a

TABLE 1 – The environment model

Action	Environment Abstraction	Description
Reads	Agents position	The cocoa pod identifies position occupied by the mirid
Changes	Surface destroyed Position updated	Part of the surface of the pod is destroyed by the mirid The mirid moved

TABLE 2 – Global variables of the environment

Variables	Description
Relative humidity	The climate gives the current relative humidity of the system
Temperature	The climate gives the current temperature of the system
Shade	The climate gives the current shade received by a part of the system

mirid and for reasons of simplicity, we assume that the mirids live and grow on one cocoa pod. However an extension of this work could consider several cocoa pods in a 3D dimension. A cocoa pod constitutes the environment like showed in Figure 1. In the mentioned figure, black points represent the places where mirids have fed themselves. Mirid’s position is represented in a 2D plan. This paper focuses on the modeling of mirids interactions through the environment without considering external interactions such as humans.



FIGURE 1 – Mirid on a cocoa pod [5]

## 2.1 Analysis

**Environment model :** For simplicity reasons, we assume that the environment in our model is restricted to the cocoa pod where the mirids live, feed themselves, grow, mate and die. Table 1 presents the environment model for our work.

We have identified some global variables that influenced the dynamics of the system. Climate parameters and shade impact the growing of the mirid and the cocoa pod. Table 2 presents the description of these global variables.

TABLE 3 – The MIRID functional role schema

<b>Role name :</b> MIRID
<b>Description :</b> This role is in charge of representing the birth, growth, mating, feeding, and death of a cocoa mirid
<b>Protocol and activities :</b> move, feed, grow, be born, mate, lay egg, die
<b>Permissions :</b> <b>Reads :</b> PosX, PosY <b>Changes :</b> Occupied_area, an area of cocoa pod occupied by the mirid Destroyed_area, an area destroyed by the feeding of mirids
<b>Responsibilities :</b> <b>Liveness :</b> $MIRID = (to\_be\_born.grow + .move.feed.[mate].[lay\_egg]).die)^n$ <b>Safety :</b> numberMirid > 2, miridMale.PosX=MiridFemale.PosX, miridMale.PosY=MiridFemale.PosY, $New\_Destination \in set\_points\_of\_cocoa\_pod,$ $Content(New\_Destination) = \emptyset$

**Preliminary role model :** The aim of this model is to describe the whole activity and procedure that can be done by a role. We identify a role in our system (MIRID). Table 3 presents the preliminary role model of our system (emphasized represented activities). To execute the MIRID role, it is important to know at which position the mirid is situated in the plan. Its actions can impact the environment by destroying a part of the pod or by occupying a set of points. A liveness property of the MIRID role specifies that a mirid, after its birth, must grow. After certain progression, it can start moving and feed itself. When it is mature, it can mate and if it is a female mirid it can lay eggs. At the end, it will die eventually. In our system, the role MIRID must guarantee that we have more than two mirids (at least both genders). For mating, female and male must be at the same position. To move in the system, there should be an empty position inside the whole system.

**Preliminary interaction model :** The preliminary interaction that can be observed here is the mating between a male mirid and a female one. This interaction starts with the stigmery<sup>1</sup> communication. The

1. This term has been introduced by the French biologist Pierre-Paul Grassé in 1959 for describing the termite behavior. It is defined as : “*Stimulation of the workers by the work that they performed.*” This term expresses the notion that the actions of an agent leave signs in the environment. These signs are perceived by itself and other agents, which determine their next actions [21]

TABLE 4 – Organizational rules

Organizational Rules	Description
Liveness rules	
MIRID	To lay an egg or to grow, there is a need for mating
safety rules	
$Mirid^\omega$	The role MIRID can be played indefinitely

female mirid emits a pheromone on the pod. When the male mirid perceives the pheromone, it will move to look for the female. When the position of the female mirid and the male mirid is the same, the mating starts. Figure 2 presents the preliminary interaction in our model.

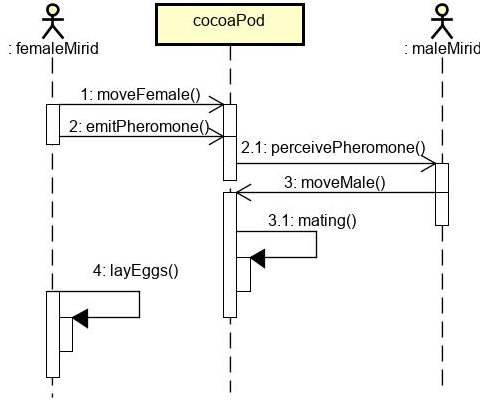

FIGURE 2 – The mating interaction protocol

**Organizational rules :** According to the authors of GAIA version 2 in [26], the main goal of organizational rules is to present general relationships between roles, between protocols, and between roles & protocols. Organizational rules have two properties : the *liveness property* which defines how the dynamics of the organization should evolve over time and the *safety property* which defines the time-independent global invariants of the organization that must be respected. The safety property of our system is to ensure the continuity of the mirid species. For this, the mirid role is played indefinitely. The liveness property of our system is to ensure that the population evolves over time. For this, the mirids must mate to create a new generation of mirids. Table 4 shows the different organizational rules of our system.

## 2.2 Architectural Design

**Organizational structure :** From the biological description of the mirid on a cocoa pod, we define the organizational structure of our system. A peer relationship is the type of relations inside our system. It means that there is an indirect conflict on food. All

agents of our system collaborate to keep the continuity of their population. Whatever the mirid ( $i$  or  $j$ ) of our system, it collaborates with the others. The male and female mirids also collaborate ( $\overrightarrow{peer}$ ). The lack of competition is due to the abundance of food. This can be simply expressed by Equation 1.

$$\forall(i, j) \in Mirid^2, i \neq j \Rightarrow i \overrightarrow{peer} j \quad (1)$$

**Role model :** After having the organizational structure, it is possible to complete the role model. This model presents the internal state of agents in the system. State-transition of the role is showed in Figure 3. It defines the specification of activities and services of the basic role and the organizational roles according to the above adopted organizational structure.

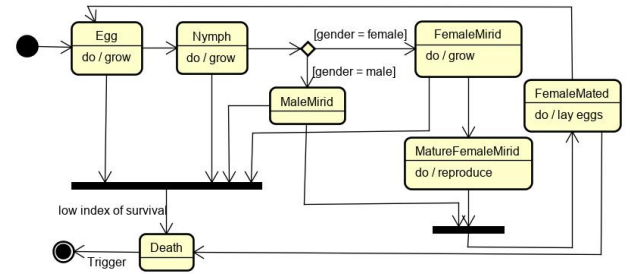

FIGURE 3 – State-Transition diagram of the role MIRID

**Interaction model :** The goal of this part is to identify new protocols or interactions deriving from the adopted organizational structure. Some interactions, notably *laying eggs* (Figure 4) and *feeding* (Figure 5), result from the organizational topology and the identification of agents.

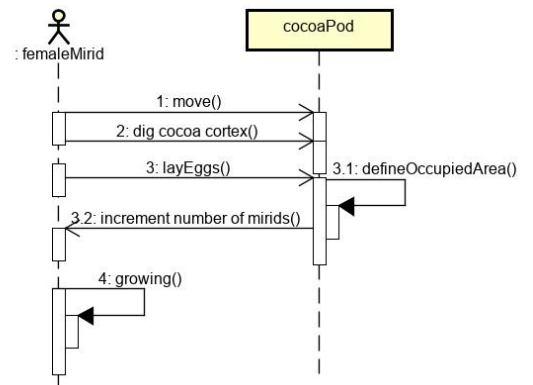

FIGURE 4 – The *lay eggs* interaction protocol

## 2.3 Detailed Design

**Agent model :** Building an agent model consists, essentially, of establishing a link between the roles and the agent. It indicates how many instances of each

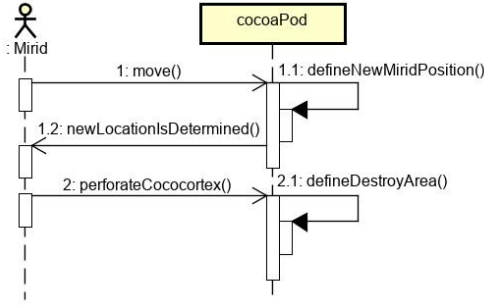

FIGURE 5 – The *feeding* interaction protocol

agent will exist in the system, and which roles each agent will implement. It permits us to specify how many instances of each class will appear in the MAS using the cardinality standard [8]. Our system has only one role named MIRID which can be played once or many times by the agent MIRID. Figure 6 shows our agent model.

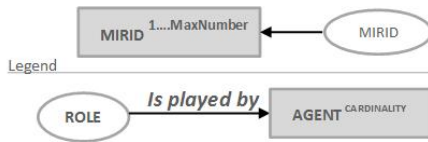

FIGURE 6 – Agent model

**Service model :** It identifies the services associated to each agent or class, with the role to be played by each agent class. Generally, the protocols, activities and liveness expressions of the role allow us to find different services that will be implemented by an agent. Agent performs at least one service, it is necessary to document the properties of services. Table 5 specifies our service model.

TABLE 5 – The service model

Services	Inputs	Pre-conditions	Post-conditions
Initialisation	Pod_area and Mirids number	Mirids number $\geq 2$ and at least one female and one male	
Moving	Destination position	Destination position is free	Occupied position
Death	Actual position	Mirids number $> 2$	Mirids number decreased
Feeding	Feed area	$\exists$ eatable area	Destroyed area

### 3 Discussion

The previous section presents our agent-based model of the mirid on a cocoa pod, which is a complex system. In order to implement such a complex system, agent-based simulation frameworks have been developed to allow transferring real-world scenarios into executable models (*i.e.* simulating the activities of mirids in a digital environment). To implement the model using agent-based simulation, some requirements should be respected :

- Specify the characteristics of our environment. The size of the pod cocoa depends on the cocoa variety and it extremely varies due to climate factors.
- Define the surface of the cocoa that should be considered according to the cocoa variety. The surface of the cocoa increase with time.
- Define the position of our initial mirid. When the sun appears, mirids concentrate on the shade-less areas, they disperse themselves when the night comes. For the moving of mirids, we shall define a set of points where the mirids can go to if they are empty. Mirids move only when the sun appears and they disappear for mating or if there is an enemy around them.
- For the reproduction, the female mirid emits a pheromone that will attract the male mirid.
- Define the probability of death of mirids at any stage of the development.

All those steps of implementation will help us implement our model using agent-based simulation. Our models, simulations and interfaces should be explainable to human users (entomologists, agricultural engineers, farmers and decision makers) in the cocoa domain. Explaining to users how intelligent systems come to their conclusions is an area of research with a history in expert systems and recommended systems [11, 14]. Recently, as intelligent systems are getting increasingly complex. eXplainable Artificial Intelligence (XAI) reemerged to push for interpreting the process of the machine learning mechanisms, and understanding the decisions of robots and agents [2].

This work is on progress, and in the future we want to add the different actions of different human users (entomologists, agricultural engineers, farmers and decision makers). We need to measure how the regularity of their actions can impact the damage caused by mirids. Therefore, the main goal of our work is to provide tools (simulators and models) for the users. The tools make a recommendation, decision, or action. Then, they provide an explanation to the user that justifies its recommendation, decision, or action. Entomologists will use these tools for the preparation of their experimentation on the fields. It will help them have an idea of the type of results that they could have.

The usefulness of our tools for agricultural engineers and farmers is that it will help in the pest surveillance and the forecasting of optimal timing for insecticide spraying. Farmers of cocoa are mostly poor, so it is important to them to have optimal timing for insecticide spraying. At the end of our simulations, we could estimate the damage caused by the mirids to the cocoa pods. This type of information is very important for decision makers and the government.

Explainability has to be handled in two steps in our system (Figure 7) :

1. From the cocoa literature, some works have been done on the mirid, especially by entomologists. We use these works to build our agent-based models. After the modelling, implementation outputs are interpreted by graphs. At this step, we need the interaction of entomologists to validate our models. They will be able to evaluate if our results are close to what they often observe in the fields. With the feedback provided by the entomologists, the model can be revisited and better explainable interfaces can be built.
2. All outputs of previous step concern directly the farmers and decision makers. Interfaces are necessary because they allow individual tracking of each agent in the system. This individual follow-up would better explain emerging behaviors, which is not the case for macroscopic modeling. Interfaces are useful to forecast the future according to parameters that they would have entered previously. Farmers could also use those outputs to have an optimal plan for the different interventions (insecticide spray) on the field. Also the entomologist could need this outputs to have a first idea of the results that they could have for their experimentations.

The ultimate goal for this work will be to explain to users the behavior of an agent-model and simulation of the mirids in a cocoa farm. This explanation will help the users understand the behavior of the mirids, and hence, help in their decision making process to prevent the damage caused by mirids to the cocoa pods in cocoa farms.

## 4 Conclusion

In this paper, an initial agent-based model representing the population dynamics of mirids interacting on a cocoa pod is presented. The model is built based on the literature and by different steps of GAIA methodology.

According to our knowledge of the literature, our work is the first agent-based model that is developed to study mirids pest. This approach will greatly improve the prospects of understanding small scale interactions between individual components of cocoa farm.

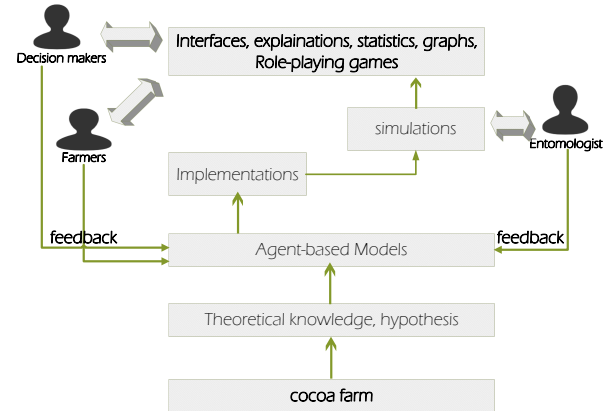

FIGURE 7 – Workflow of our future work

In terms of integrating pest management strategy, this model aims to create a comprehensively design-specific, detailed, and integrated systems to control specific pest species within specific crop zones. With enough refinement and insight, the behavior of mirids will be possible to evaluate at a specific zone. Next areas of our work could be : (i) the simulation and validation of our model ; (ii) the evaluation of damage caused by the mirids ; (iii) the integration of the impact of human actions (spread of insecticide) on the mirids population ; (iv) how to auto-regulate the population of mirids by the use of ants for biological control of insect ; (v) testing our models and simulations with entomological research data.

## Références

- [1] J. C. Anikwe, A. A. Omoloye, P. O. Aikpokpotion, F. A. Okelana, and A. B. Eskes. Evaluation of resistance in selected cocoa genotypes to the brown cocoa mirid, *Sahlbergella singularis* Haglund in Nigeria. *Crop Protection*, 28(4) :350–355, 2009.
- [2] S. Anjomshoae, A. Najjar, D. Calvaresi, and K. Framling. Explainable agents and robots : Results from a systematic literature review. In *Proc. of the 18th International Conference on Autonomous Agents and Multiagent Systems*, 2019. To appear.
- [3] R. Babin. *Contribution à l'amélioration de la lutte contre le miride du cacaoyer Sahlbergella singularis Hagl. (Hemiptera : Miridae). Influence des facteurs agro-écologiques sur la dynamique des populations du ravageur.* PhD thesis, Université Paul Valéry-Montpellier III, 2009.
- [4] R. Babin, J. C. Anikwe, L. Dibog, and J. P. Lumaret. Effects of cocoa tree phenology and canopy microclimate on the performance of the mirid bug

- Sahlbergella singularis. *Entomologia Experimentalis et Applicata*, 141(1) :25–34, 2011.
- [5] R. Babin, D. H. Bisseleua, L. Dibog, and J. P. Lumaret. Rearing method and life-table data for the cocoa mirid bug *Sahlbergella singularis* Haglund (Hemiptera : Miridae). *Journal of Applied Entomology*, 132(5) :366–374, 2008.
- [6] R. Babin, C. Djieto-Lordon, C. Cilas, L. Dibog, R. Mahob, and C. F. B. Bilong. True Bug (Heteroptera) Impact on Cocoa Fruit Mortality and Productivity. *Journal of Economic Entomology*, 105(4) :1285–1292, 2012.
- [7] R. Babin, C. Fenouillet, T. Legavre, L. Blondin, C. Calatayud, A. M. Risterucci, and M. P. Chapuis. Isolation and characterization of twelve polymorphic microsatellite loci for the cocoa mirid bug *sahlbergella singularis*. *International Journal of Molecular Sciences*, 13(4) :4412–4417, 2012.
- [8] M. Cossentino, V. Hilaire, A. Molesini, and V. Seidita. *Handbook on agent-oriented design processes*. Springer, 2014.
- [9] C. M. Duarte, J. S. Amthor, D. L. DeAngelis, L. A. Joyce, R. Maranger, M. Pace, J. Pastor, and S. Running. The limits to models in ecology. *Models in ecosystem science*, pages 437–451, 2003.
- [10] A. Fountain and F. Hütz-Adams. Baromètre du cacao 2015. *Créat. Commons Licens. Attrib.-ShareAlike 4.0 Int*, 2015.
- [11] N. Gilbert. Explanation and dialogue. *The Knowledge Engineering Review*, 4(3) :235–247, 1989.
- [12] V. Grimm. Mathematical models and understanding in ecology. *Ecological modelling*, 75 :641–651, 1994.
- [13] M. A. Janssen. Internet encyclopedia of ecological economics : Agent-based modelling. 2005.
- [14] R. Kass, T. Finin, et al. The need for user models in generating expert system explanations. *International Journal of Expert Systems*, 1(4), 1988.
- [15] N. Kouamé, F. K. N’Guessan, H. A. N’Guessan, P. W. N’Guessan, and Y. Tano. Variations saisonnières des populations de mirides du cacaoyer dans la région de l’indénié-djuablin en côte d’ivoire. *Journal of Applied Biosciences*, 83(1) :7595–7605, 2014.
- [16] R. J. Mahob, R. Babin, G. M. ten Hoopen, L. Dibog, Yede, D. R. Hall, and C. F. Bilong Bilong. Field evaluation of synthetic sex pheromone traps for the cocoa mirid *Sahlbergella singularis* (Hemiptera : Miridae). *Pest Management Science*, 67(6) :672–676, 2011.
- [17] E. Malézieux, Y. Crozat, C. Dupraz, M. Laurans, D. Makowski, H. Ozier-Lafontaine, B. Rapidel, S. De Tourdonnet, and M. Valantin-Morison. Mixing plant species in cropping systems : concepts, tools and models : a review. In *Sustainable agriculture*, pages 329–353. Springer, 2009.
- [18] M. Moglia, S. Cook, and J. McGregor. A review of Agent-Based Modelling of technology diffusion with special reference to residential energy efficiency. *Sustainable Cities and Society*, 31 :173–182, 2017.
- [19] M. A. Ngo Bieng, C. Gidoïn, J. Avelino, C. Cilas, O. Deheuvels, and J. Wery. Diversity and spatial clustering of shade trees affect cacao yield and pathogen pressure in Costa Rican agroforests. *Basic and Applied Ecology*, 14(4) :329–336, 2013.
- [20] I. C. Organization. Icco quarterly bulletin of cocoa statistics. *The International Cocoa Organization*, XLII(3), 2016.
- [21] H. Parunak, S. A. Brueckner, R. Matthews, and J. Sauter. How to calm hyperactive agents. In *Proceedings of the second international joint conference on Autonomous agents and multiagent systems*, pages 1092–1093. ACM, 2003.
- [22] N. Quang Huynh, T. Nguy en Huu, A. ud Grignard, H. X. Huynh, and A. Drogoul. Coupling equation based models and agent-based models : example of a multi-strains and switch SIR toy model. *EAI Endorsed Transactions on Context-aware Systems and Applications*, 4(11) :152334, 2017.
- [23] J. Sarfo, C. Campbell, and D. Hall. Design and placement of synthetic sex pheromone traps for cacao mirids in ghana. *International Journal of Tropical Insect Science*, 38(2) :122–131, 2018.
- [24] D. Tapi, B. Beihle, S. Bowong, and Y. Dumont. Models for Miridae, a cocoa insect pest. Application in control strategies. *Mathematical Methods in the Applied Sciences*, (March) :1–24, 2018.
- [25] M. Wooldridge, N. R. Jennings, and D. Kinny. The gaia methodology for agent-oriented analysis and design. *Autonomous Agents and multi-agent systems*, 3(3) :285–312, 2000.
- [26] F. Zambonelli, N. R. Jennings, and M. Wooldridge. Developing multiagent systems : The gaia methodology. *ACM Transactions on Software Engineering and Methodology (TOSEM)*, 12(3) :317–370, 2003.